

# INSTALLATION & OPERATION MANUAL

## MODEL NUMBERS:

25-PDV, 55-SHP22, and 55-TRP22

25-PDVE, 55-SHP22E, and 55-TRP22E

*Thank you for purchasing this product from a fine line of heating equipment. We wish you many years of safe heating pleasure with your new heating appliance.*

### ***Save These Instructions.***

**IMPORTANT: IF YOU HAVE A PROBLEM WITH THIS UNIT DO NOT RETURN IT TO THE DEALER. CONTACT CUSTOMER SERVICE @ 1-800-245-6489.**

#### ***Mobile Home Use:***

These freestanding pellet units are approved for mobile home or doublewide installation with outside combustion air hook-up. See "Flue System" section of manual.

Mobile home installation should be in accordance with the Manufactured Home and Safety Standard (HUD), CFR 3280, Part 24.

#### **WARNING: Do Not Install in Sleeping Room**

**CAUTION: The structural integrity of the mobile home floor, wall and ceiling/roof must be maintained.**

---

---

### **Please Note the Following Precautionary Statements:**

**NOTE: WE DO NOT RECOMMEND PELLET STOVES AS YOUR ONLY SOURCE OF HEAT.**

England's Stove Works highly recommends the use of smoke detectors and Carbon Monoxide detectors with any hearth product, including this unit. Follow all manufacturer's instructions when using smoke or Carbon Monoxide detectors.

**CAUTION: Please read this entire manual before installation and use of this pellet fuel burning room heater.**

Keep children, furniture, fixtures and all combustibles away from any heating appliance.

#### **WARNING: USE OF OUTSIDE AIR IS MANDATORY WITH THIS UNIT.**

DO NOT OPERATE UNIT WITH HOPPER OPEN. LID MUST BE SHUT AND TIGHTLY SECURED.

***DO NOT OPERATE WITH DOOR OPEN***

### **SAFETY NOTICE**

**FAILURE TO FOLLOW THESE INSTRUCTIONS COULD RESULT IN PROPERTY DAMAGE, BODILY INJURY OR EVEN DEATH. FOR YOUR SAFETY AND PROTECTION, FOLLOW ALL THE INSTALLATION INSTRUCTIONS. CONTACT YOUR LOCAL BUILDING OR FIRE OFFICIALS FOR RESTRICTIONS AND INSTALLATION INSPECTION REQUIREMENTS (INCLUDING PERMITS) IN YOUR AREA.**

Questions? Need Parts or Options? [www.englishstoveworks.com](http://www.englishstoveworks.com)



Rev. 10/05

**A letter from our Technical Support department:**

**Thank you for purchasing this fine product from England's Stove Works!**

England's Stove Works was started, and is still owned by, a family that believes strongly in a "Do It Yourself" spirit – that's one reason you found this product at your favorite "Do It Yourself" store.

We intentionally design and build our stoves so that any homeowner can maintain his or her unit with basic tools, and we're always more than happy to show you how to do the job as easily and as inexpensively as possible.

From our free, downloadable service sheets; to our Pellet Service Video; to our new "wizard-style," click-through Troubleshooting guide on our web site, we have always tried to help our customers stay "heat-ready," especially when oil and electricity prices continue to skyrocket.

Please look at our vast Help section on our web site and call our Customer Service department at (800) 245-6489 if you need any help with your unit. We are nearly always able to help "walk you through" any repairs, problems or questions you may have.

**PLEASE NOTE:** While information obtained on our web site and through our 800 number is always free of charge, there will be a service charge incurred with any "on-site" repairs or maintenance that we may arrange.

*Wishing you years of efficient, quality and "comfy" heating,*  
England's Stove Works  
Technical Support Department

**[www.englishstoves.com](http://www.englishstoves.com)**

**(800) 245-6489**

<p>IF YOU HAVE A PROBLEM WITH THIS UNIT DO NOT RETURN IT TO THE DEALER. CONTACT CUSTOMER SERVICE at 1 (800) 245-6489.</p>
---

# IMPORTANT INFORMATION

1. Check local installation codes for your area. Call your Homeowner's Insurance representative for inspection of your stove's installation.
2. Read and comply with the instructions in this manual.
3. This unit should be tested (dry run) before loading pellets for 20 minutes. The stove should automatically shut itself off after the 20-minute dry run.
4. **Your stove is designed to burn Premium Pellets.** Pellets with high ash content will burn dirty and require the unit to be cleaned more often.
5. Be sure your pellets are not damp or wet. Keep sawdust out of the unit.
6. Use three-inch (3") U.L.-approved PELLET VENT TWIST-LOCK PIPE when installing this stove and follow the manufacturer's specifications for installation and clearances (we highly recommend Simpson Dura-Vent pellet twist-lock pipe). Even though this pipe interlocks, it is a good idea to seal all connections with high temperature silicone. Use at least three screws to secure the pipe to this unit's exhaust blower. Also, if you do not use U.L.-approved twist-lock pellet pipe, be sure to use U.L.-approved Pellet Vent pipe, and fasten each joint of the pipe with at least three screws.
7. Outside combustion air is mandatory for these units to work properly. Make this connection using a 1 1/8" I.D. metal pipe (steel, aluminum or copper) and coupler. Be sure to secure the pipe to the unit with a clamp or aluminum tape. The outside end should be covered (screened) to prevent any foreign matter from entering the system. Try to keep the number of bends in this pipe to a minimum. Our Part Number PU-OAK (Outside Air Kit with flex pipe) can be used. It can be purchased from your dealer, or by calling (800) 516-3636 or logging on to [www.englishsstoveworks.com](http://www.englishsstoveworks.com). NOTE: If an older unit, measure the opening to determine what size pipe to use. NOTE: If the total run of the connection exceeds 6', use 3" metal pipe and coupler instead.
8. Regularly inspect the burn pot area and, if any crust forms, remove it with a poker.
9. The ash in the burn pot should be removed regularly, depending on your burn rate. The area to the right and left of the burn pot is for ash storage; keep the air holes in the burn pot clean for a more efficient burn. Check your exhaust system frequently. Refer to "Ash Removal and Disposal" section.
10. Keep pellets and all other combustible materials a safe distance from the unit.
11. This unit will require floor protection if installed on a combustible surface. The minimum floor protector for this unit is 36" x 36" which should give you at least six inches (6") of protection at the rear and each side, and six inches (6") minimum in the front of the unit.
12. Horizontal runs should not exceed four feet (4') with a maximum vertical flue height of thirty five feet (35'). At fifteen feet (15'), the pipe should be increased to four inch (4") pellet vent pipe.

**IMPORTANT NOTICE:** This unit must be properly installed to prevent the possibility of a house fire or "smoke-back." The instructions must be strictly adhered to. Do not use makeshift methods or material which may compromise the installation. Your unit requires periodic maintenance and cleaning (refer to manual). Failure to maintain your unit may lead to a variety of problems, including but not limited to smoke spillage into the home. England's will not be liable for consequential or indirect damages to property or persons resulting from the use of this product.

13. This unit should be turned off and allowed to cool prior to cleaning. Any ashes should be kept in an airtight metal container and not disposed of until they are completely cooled.
14. Read the instructions thoroughly, including instructions concerning the digital control board, and save them for future reference.
15. Do not allow paint, chemicals or construction dust on or near your unit. Do not allow liquid or ANY foreign materials on or inside your unit. Shut your unit down and cover it when painting, construction or similar activity is taking place. Wipe and clean your unit after any construction is done in your home, or if any foreign material gets on or inside your unit. You may also need to remove the rear and side cover plates to your unit (unplug unit first) and vacuum and clean the motors and inside of your unit.
16. Improper gasket maintenance, including failure to replace gaskets, can cause air leaks resulting in smoke-backs.
17. Remember that, as with any appliance, there is user responsibility involved, including installation, operation and maintenance of this product. Be sure to check local codes, and call Customer Service at (800) 245-6489 if you have any questions.
18. **Be sure to follow the directions of all manufacturers of third party products that you use, including exhaust pipe, etc. Never use gasoline, lantern fuel, charcoal lighter fluid, diesel fuel or any other flammable liquid to start the fire. If you manually start your unit, recommended fire starter materials are: Wax-impregnated wood chips, cardboard cubes or firestarter gel designed for pellet stoves (see section on Manually Starting Unit). Follow any manufacturer's directions for these products, and NEVER place gel or any firestarter on any hot surface or hot coals. Never apply any firestarter products of any kind to a hot surface or hot coals.**
19. **Basement Installation:** We recommend basement installation be performed only by a professional installer. For basement installations, a 3" (three inch) pipe and coupler must be used for Outside Combustion Air, and a minimum clearance of 3' (three feet) must be maintained from the ground to the pellet vent exhaust pipe outside the dwelling. Keep in mind that each elbow used reduces draft by 15%; it is good practice to add 3' (three feet) of vertical rise for each elbow used. Example: After the 2<sup>nd</sup> elbow used, have 6' (six feet) of vertical rise before terminating your vent pipe.

## UNIT PREPARATION

1. Attach the spring handle to the door by turning it counterclockwise. **Important: Also check hopper latches – must be tight so that the top is sealed to prevent back-burn.**
2. Test your 110-volt outlet for current and then plug in the unit. **(We highly recommend a surge protector for our pellet unit, as the control panel is electronic).**
3. It is important to note that this stove is equipped with a dual auger system. The top auger runs intermittently and drops pellets to the bottom auger; the bottom auger runs constantly and simply pushes the pellets forward to the burn pot. The control board ("Heat Range") setting determines the top auger feed rate.
4. The stove has a digital read-out control board and is started by pressing the "ON"

touch pad. This will start the upper auger, bottom auger and exhaust blower. The room air blower will start later as the stove reaches the pre-set blower temperature (see “Control Board” section for further explanation).

5. Check to be sure both augers and the exhaust blower are operating before connecting the unit to the flue system. Be sure to “dry run” your unit for 20 minutes before connecting it to the flue (it should stop automatically after 20 minutes).

### **Proper Impingement (Baffle) Plate Placement in Pellet Stove Firebox**

Occasionally in shipping, the impingement (baffle) plate may shift out of its proper position. If this is the case with your stove, follow these instructions to return the plate to its proper position.

1. Remove the plate from the stove, holding the plate by its tab handle, with the cutout notch facing upwards.

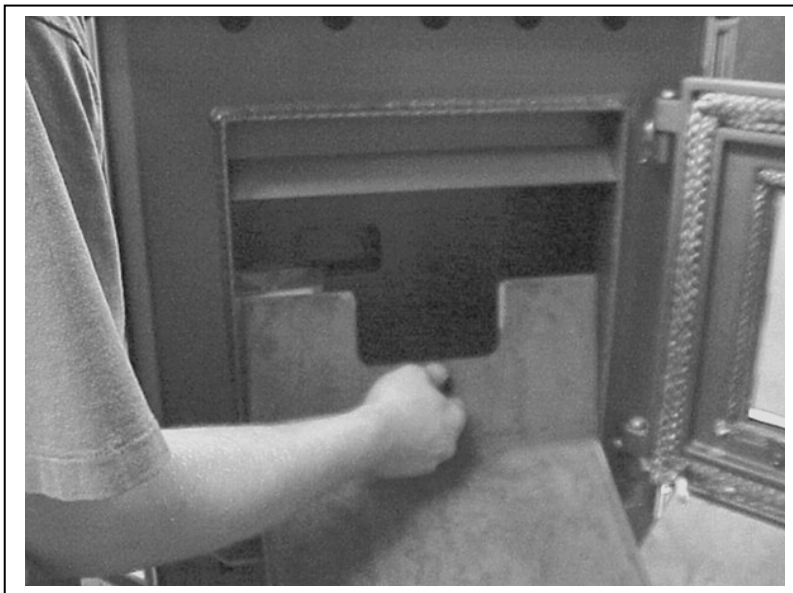

2. Turn the notched end into the doorway (as shown above), and lift the plate up to allow the bottom of the plate to fit in the doorway.
3. Let the bottom of the plate rest on the firebox, and then push the bottom of the plate flush against the back wall of the firebox. At this point, the plate will lean forward (toward the front of the stove) slightly, and will come in contact with the front of the stove above the door.
4. Finally, center the plate on the firebox, so that it will be centered above the fire when the stove is in operation.

Customer Service: (800) 245-6489

[www.englishstoveworks.com](http://www.englishstoveworks.com)

## FLUE SYSTEM

**Caution: Follow the pipe manufacturer's installation instructions and directions for passing through combustible walls and ceilings.**

***Be sure to check local codes in your area.***

**NOTE: See the installation drawing later in this manual (Illustration 1).**

This unit is equipped with a negative draft system that pulls combustion air through the burn pot and pushes the exhaust air out of the dwelling. If this unit is connected to the flue system other than the way explained in this manual, it will not function properly.

*For any of these installations, keep in mind that each elbow used reduces draft by 15%; it is good practice to add 3' (three feet) of vertical rise for each elbow used. Example: After the 2<sup>nd</sup> elbow used, have 6' (six feet) of vertical rise before terminating your vent pipe.*

### Pellet Vent Pipe

The UL approved pellet vent pipe that we recommend is a twist lock system; however, it is still recommended that high temperature silicone be used at each joint. England's Stove Works recommends the use of Simpson Dura-Vent® twist-lock pipe (if you use other pipe, consult your local building codes and/or building inspectors, and secure each joint with at least three screws—see Important Information, above). *Do not* use "B" vent gas pipe or galvanized pipe with this unit. The pellet pipe is designed to disassemble for cleaning and should be checked several times during the burning season — pellet vent pipe is not furnished with the unit and must be purchased separately. **Do not install a flue damper of any kind in this system, and do not connect this unit to a flue system serving another heating appliance.**

### Through the Wall

To vent the unit through the wall, connect the pipe adapter to the exhaust motor adapter. If the exhaust adapter is at least eighteen inches (18") above ground level, a straight section of pellet pipe can be used to initially pass through the wall (see Ill. 1). Your dealer or our factory should be able to provide you with a kit that will handle most of this installation, which will include a wall thimble that will allow the proper clearances through a combustible wall. Once outside the structure, a three-inch (3") clearance should be maintained to the outside wall and a clean out tee should be placed on the pipe that extends through the wall. We recommend a minimum of three feet (3') of vertical pipe with a 90-degree turn away from the house. At this point, a one-foot (1') section and horizontal cap will complete the installation (see Illustration 1).

A wall strap should be placed just below the last 90-degree section to make the system more stable. If you live in an area that has heavy snowfall, it is recommended the installation be taller than three feet (3') to get above the snowdrift line.

The same type installation can be used if your stove is below ground level by adding the clean-out section and vertical pipe inside until ground level is reached. However, we recommend basement installation be performed only by a professional installer. For basement installations, a 3" (three inch) pipe and coupler must be used for Outside Combustion Air, and a minimum clearance of 3' (three feet) must be maintained outside the dwelling from the ground to the Pellet Vent Exhaust Pipe.

The through-the-wall installation is the least expensive and simplest installation. In a through-the-wall installation you should be mindful of the snowdrift line, as well as dead grass and leaves. We recommend a three foot (3') minimum vertical rise on the inside or the outside of the dwelling. Never terminate the end vent under a deck, in an alcove, under a window or between two windows. Call (800) 516-3636 to inquire about the AC-3000 Through-the-Wall Kit.

### Through the Ceiling

When venting the stove through the ceiling, the pipe is connected the same as through the wall, except the clean out tee is always on the inside of the house, and a 3" adapter is added before the clean-out tee. You must use the proper ceiling support flanges and roof flashing supplied by the pipe manufacturer -- follow the pipe manufacturer's directions and Illustration 1 in this manual. It is important to note that if your vertical runs of pipe are more than fifteen feet (15') at this point, the pellet vent pipe should be increased to four inches (4") in diameter. Do not exceed four feet (4') of pipe on a horizontal run, and do attempt to use the least number of elbows in the flue system. If an offset is used it is better to install a 45-degree elbow whenever possible. *Please remember, installing elbows may inhibit your draft by up to 15% per elbow.*

### Existing Flue System

If you are replacing a wood stove with a pellet unit the chimney or pipe should be thoroughly cleaned before proceeding with the installation. The flue system should be either masonry or a UL approved pre-manufactured Class A flue system. The flue thimble should be either six inches (6") or eight inches (8") and the proper reducer (6" to 3" or 8" to 3") can be purchased at your local dealer. Connect a three inch (3") tee with clean-out to the pipe adapter -- seal this with high temperature stove cement, then extend your pipe to the installed reducer at the thimble. If the thimble is in the ceiling, the pipe will go straight up, but if the thimble is in the wall another 90-degree elbow will be required to make the connection.

### Outside Air (Outside Combustion Air Intake)

Outside air is mandatory for this unit to operate properly. This unit has been designed and tested with this connection, because so many homes are airtight and there is not adequate combustion air available inside the dwelling. The air intake pipe is located on the bottom side of the burn pot (from the rear) and measures 1 ½" inside diameter (I.D.). The connection can be made with a metal 1 7/8" I.D. coupler and pipe (see "Important Information" section of manual), and should exit through the wall. Be sure to secure the pipe to the unit with a clamp or aluminum tape. The outside end of the pipe should be covered (screened) to prevent foreign matter from entering the system. Our Outside Air Kit (Part Number PU-OAK) can be used. If the unit is located below ground level, you will need to run the pipe up and then outside the dwelling. NOTE: If the total run of the connection exceeds 6', if more than 2 elbows are used, or if a basement installation, use 3" metal pipe (and coupler) instead. *Note:* If an older unit, measure the opening to determine what size pipe to use or couple to.

### Mobile Home Installation

Secure the heater to the floor using the two holes in the pedestal. If the unit is on a combustible surface, you will need to drill matching holes in the floor protection that you choose (see Floor Protection section). Do not disturb the structural integrity of the home, and be sure the unit is permanently electrically grounded to the chassis of your home. Remember that outside combustion air is mandatory, and not to install the unit in a sleeping room of the home.

### Important Notes Concerning Installation:

**\*IMPROPER INSTALLATION:** The manufacturer will not be held responsible for damage caused by the malfunction of a stove due to improper venting *or* installation. Call (800-245-6489) and/or consult a professional installer if you have any questions.

**IMPORTANT:** Improper hook-up (too much pipe, too many elbows, etc.) will cause the unit not to operate. Call Customer Service (800-245-6489) if you have questions about your hook-up or if your unit will not operate.

## Freestanding Pellet Installation

**Caution: Follow the pipe manufacturer's installation instructions and directions for passing through combustible walls and ceilings. Check local codes in your area.**

**Illustration 1**

Must have minimum 3" adapter before tee for longer run.  
For shorter run (such as Masonry Connection below), tee alone is acceptable.

Our Part AC-3000 is acceptable for through-the-wall installation. (AC-3100 for 4000+ ft. installations.)

Basement Installation should be performed by professional installer. Use 3" metal pipe and coupler for Outside Combustion Air. Minimum 3' clearance from ground to the Pellet Vent Exhaust Pipe.

Outside AIR IS MANDATORY for this unit to operate properly.

Masonry Connection

1. If 3" flue pipe exceeds 15' in length, increase to 4" flue pipe for remaining flue connections.
2. Total flue length should not exceed 35'.
3. Horizontal run not to exceed 4'.
4. Floor protector required: Min. size 36" x 36".
5. If the total run of outside air connection exceeds 6', if more than 2 elbows are used, or if a basement install, use 3" metal pipe (and coupler) instead.
6. **Outside Air is mandatory for proper safe operation.**

## FLOOR AND WALL PROTECTION

### Floor Protection

If your floor is constructed of a non-combustible material such as brick or concrete, there is no need for floor protection. If the floor is constructed of a combustible material such as hardwood, linoleum, or carpet, then you will be required to use floor protection between the unit and the combustible. The protection should be U.L. approved or equal, and should be large enough to provide a minimum of six inches (6") behind and on both sides of the stove. The clearance in front of the stove should be at least six inches (6"). This freestanding pellet unit will need a minimum 36" x 36" floor protector.

### Wall Protection

From the rear and the sides of this stove only six inches (6") of clearance is required to paneling, wallpaper or drywall. The pellet vent pipe would require the standard three inches (3") clearance, or as recommended by the manufacturer. Normally additional wall protection is not required with this type unit.



## OPERATING INSTRUCTIONS

### CAUTION: DO NOT OPERATE WITH THE DOOR OPEN.

If door is left open (approximately) two minutes, unit will stop feeding and fire will go out.

Do not burn trash (paper bags, etc.) in this unit.

This stove has an induced draft system and is designed to operate continuously, as frequent shutdown is not required. The digital control board operates the unit with a time delay-relay system; this system controls the top auger feed rate by operating for a predetermined number of seconds while the bottom auger runs constantly. The setting of the “**Heat Range**” touch pad will control the heat output and the amount of pellets the unit will burn (see “Control Board” section and Ill. 2). Note: This stove is using solid fuel and will not restart automatically. \* *NOTE: Blower Speed will automatically be adjusted to the desired Heat Range that you select.*

### Horizontal Feed System

This unit has a top and a bottom auger that are separated by four inches (4”); a 1-RPM motor drives each auger. The top auger drops pellets to the bottom auger tube, and the bottom auger pushes the pellets forward to the burn pot. This ensures there is no build-up of fuel in the bottom auger tube. As pellets enter the burn pot the combustion air is drawn across the fuel.

### START- UP PROCEDURE

**Caution - Never use gasoline, lantern fuel, charcoal lighter fluid, diesel fuel, or any other flammable liquid to start the fire.**

1. Be sure the hopper is clean and free from foreign materials. Be sure there is current at your outlet (we do recommend a surge protector with our unit).
2. **Before** your first fire **dry run your unit (with no pellets in the hopper)** for 20 minutes. Press the “ON” button to begin the dry run. After the 20 minute dry run, the control board will return to “OFF.” An error code will appear in the Heat Range and the Blower Speed windows as “**E-2,**” which means the unit failed to start normally. After this code is received and you are sure the unit is working properly, fill the hopper with wood pellets. Do not allow any part of the bag or any foreign material in the hopper, as this may jam the augers. Ensure that all pellet matter is cleared from the hopper lid gasket, make sure the hopper lid latches and the door of the unit are securely closed and press the “ON” button; this will clear the error code and restart your unit.

### Start-Up

When the “ON” button is pressed from a cold start, the unit is in “Start-Up” (after 3 seconds, there will be an “S U” in the Heat Range and Blower Speed windows to verify this). While in this mode, the unit has a preset heat range and will remain in this mode for 20 minutes to prevent the unit from over-firing. During this start-up period you can set the Control Board at the setting you desire; after the start-up is complete, the unit will run at the user setting.

### Manually Starting Your Unit

If for some reason the unit does not ignite after pressing the “ON” button and going through the Start-up procedure, clean any pellets out of the burn pot (to prevent over-feeding), and manually start your unit. This may be done simply by placing a handful of new pellets in the burn pot, then spreading a small amount of pellet fire starter gel over the pellets and igniting them. After the pellets ignite, close the door to your unit and press the “ON” button (if the door is closed before the pellets fully ignite, the Exhaust Blower could put out the fire). Recommended fire starter materials: Wax-impregnated wood chips, cardboard cubes or firestarter gel designed for pellet stoves. Follow any manufacturer’s directions for these products, and NEVER place gel or

any firestarter on any hot surface or hot coals. Never use gasoline, lantern fuel, kerosene, charcoal lighter fluid, diesel fuel or any other flammable liquid to start the fire.

If you have any further problems with the Auto-Start Igniter, call Customer Service.

### **E-Codes**

“E-Codes,” or Error Codes, are codes that will appear in the Heat Range and Blower Speed windows of the Control Board if your unit experiences problems. If you receive any of these codes, first attempt to reset your unit by pressing the “ON” button (only once). If the unit continues to display any E-Code(s), please contact Customer Service at (800) 245-6489 before further attempting to restart your unit.

1. E-1 = Vacuum Loss
  2. E-2 = Fail to Start
  3. E-3 = Over Temperature Limit
- NOTE: “E-0” indicates “No Error”

**First Fire:** Adjust the “Heat Range” to a “5” setting and allow the stove to burn in this manner for *at least three (3) hours*. This will allow the unit to “cure out” as the paint and the oils from the manufacturing process burn off. We recommend you open doors and windows in your dwelling during this process.

**Subsequent Cold Starts:** In a cold start situation, the unit should be operated at a “5” setting until the room air blower begins to operate.

**NOTE:** The start-up cycle for this unit with the Auto-Start Igniter is 13 minutes. **Press the “ON” button only once on start-up.** Pressing the “ON” button a second time during the start-up cycle will cause the start-up cycle to begin again.

***IMPORTANT:*** If the unit fails to start properly, or does not properly complete the Shut-Down procedure, **open the closest outside door and a window to eliminate the home’s natural draft BEFORE opening the stove’s door or hopper lid.** This will allow any smoke to exit through the external air hook-up instead of spilling into the home.

### **SHUT-DOWN PROCEDURE**

WARNING: NEVER SHUT DOWN THIS UNIT BY UNPLUGGING IT FROM THE POWER SOURCE.

Refer to the following instructions:

Press the “OFF” touch pad to put the stove in the “Shut-Down” mode. There will be an “S D” in the Heat Range and Blower Speed windows while the unit is shutting down to verify this. At this time the red light above the “OFF” pad will illuminate. When the “OFF” pad is touched the top auger will instantly stop feeding pellets to the bottom auger tube, but the room air blower, exhaust blower and bottom auger will continue to operate. When the internal temperature drops to 95 degrees the room air blower will cease to operate, and when the internal temperature drops to 90 degrees the bottom auger and exhaust blower will stop. The red light will then shut off and the entire stove will be shut down. The hotter the unit is operating, the longer it will take for the stove to complete the Shut-Down cycle.

**Note:** The unit will exit the Shut-Down cycle if you press any buttons during Shut-Down.

**Note:** If the room temperature stays above 70 degrees the stove will remain in the Shut Down mode for 60 minutes, regardless of the temperature reading at the heat sensor. If the stove stays on longer than 60 minutes the unit will automatically turn off.

## DAILY OPERATION

### Refueling the Unit

Always press the “OFF” touch pad before refueling. This stove has a (approximately) 60-lb. hopper, and should be refilled when the hopper level drops to three or four inches.

**Note:** The hopper lid will be warm; therefore, you should always use some type of hand protection. NEVER place your hand near the auger while the stove is operating.

**Note:** Always ensure that all pellet matter is cleared from the hopper lid gasket before closing. Be sure to close and latch hopper **securely** before re-firing. Do not operate this unit with the hopper lid open or unsecured.

### Power Outage

If the power to the unit is interrupted for approximately three minutes or less, the unit will resume operation when power is restored according to the following table:

Unit's State Before Power Loss	State When Power Returns
ON	Start-Up
Start-Up	Start-Up
Shut-Down	Shut-Down
OFF	OFF

If the power is interrupted for more than (approximately) three minutes, the unit will be “OFF” when power returns.

**Important:** Do NOT open the hopper lid or the door to the unit during power outage. Open the closest outside door and a window to eliminate the home's natural draft.

Wait for power to be restored and then press the “ON” button to re-start the unit, if necessary.

We highly recommend the use of a surge protector with your unit, as power surges and failures can affect the operation of any electrical appliance.

We do not recommend leaving home with the stove on the higher heat ranges; it is recommended that the stove be left on the lower heat ranges (Heat Range setting 1 or 2).

**NOTE:** Remember: 1) It is **very** important for the unit to be vented properly (see instructions on Outside Air), as the natural draft is needed to clear the smoke from the stove. 2) Do not open the hopper lid (or the unit's door). This may cause fire to burn in the hopper.

### Fuel Outage

If the unit should run out of pellets, simply reload the hopper and press the “ON” button (only once) to re-start the unit. If the unit runs without pellets, after one hour the unit will shut down.

**NOTE:** Even if flames are visible inside the fire box always press the “ON” button to ensure that your unit will restart.

### Combustion Blower Failure

If the Combustion (exhaust) Blower should fail on this unit, a Vacuum Shut-Down Switch will automatically stop the stove. This will shut your unit completely off, and there will be an “E-1” code in the Heat Range and Blower Speed windows on the Control Board. At this point you will need to contact Customer Service at (800) 245-6489.

**NOTE:** It is **very** important for the unit to be vented properly (see instructions on Outside Air), as the natural draft is needed to clear the smoke from the stove.

NOTE: The instructions below concerning the cleaning of the burn pot and wear plate area are **especially important** to the function of your stove. Failure to follow them regularly can result in burn-back and can damage your unit and/or void your warranty.

## ASH REMOVAL AND DISPOSAL

**IMPORTANT:** While the amount of ash generated by this unit is not excessive compared to log-burning woodstoves, keeping the unit clean and free of ash is essential for peak performance. Too much ash build-up hampers airflow and reduces the unit's efficiency, and can cause smoke-back. Follow these directions at least as frequently as the schedule below, or more often if needed.

### Daily Ash Maintenance

Press the "OFF" touch pad and allow the stove to burn for five (5) minutes prior to opening the door. A long-handled screwdriver or long-handled putty knife can be used to scrape off any build-up or crust in the burn pot area. This can then be pushed to the left or right into the ash storage area.

### Semi-Weekly Ash Removal

Twice each week: Shut the unit down by pressing the "OFF" pad and allowing the unit to go through the complete Shut-Down cycle. Allow the unit to completely cool down and then remove the ashes with a scoop. The ashes should be placed in a non-combustible container with an airtight lid and should always be placed on a non-combustible surface or on the ground until completely cooled and free of hot cinders.

Once the ash is removed, the burn pot should be given a thorough inspection. Remove and clean the burn pot wear plate (refer to the exploded diagram in the rear of this manual – Illustration 4, and the close-up diagram shown here), and remove any ash build-up in the area below the wear plate. Also, be sure there are no ashes or obstructions in the tube under the wear plate. Check for any build-up in the front of the burn area. Clean out all air holes (if necessary a 1/8" drill bit can be used) --these air holes should be kept clean, as they supply combustion air under and around the pellet fuel. The burn pot assembly should also be thoroughly cleaned, including the burn box. When replacing the wear plate, ensure that it lies flat in the firebox and no gaps (from ash residue) are under it. **IMPORTANT: Ash build-up under the wear plate can cause the unit to malfunction.**

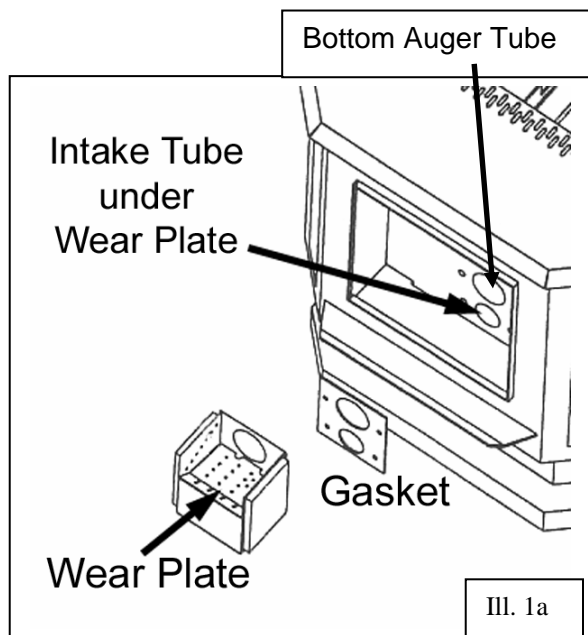

### Monthly Ash Removal

The large baffle plate (12-5/8" x 9-3/8") that rests above and behind the burn pot (refer to the section on "Proper Impingement Plate Placement" and the exploded diagram in the rear of this manual – Illustration 4) should be removed monthly. This can be done by lifting up the plate and pulling it out. The area behind the plate should then be cleaned thoroughly, and the plate placed back in the original position.

Use a screwdriver or chisel and break any creosote build-up in the front of the unit, where the pellets are fed into the burn pot from the Bottom Auger Tube (see Ill. 1a). Moisture in the pellets and resulting build-up in this area can cause the bottom auger to "squeal" or squeak.

Also inspect your flue pipes, and remove ash buildup from the clean-out tee.

## Annual Cleaning

The stove and the flue system should be given a complete cleaning at the end of the heating season. Remove the burn pot assembly, clean it thoroughly, and re-install it (refer to Illustration 4); this will require new gasket for the burn pot. Be sure to tighten the set screws when you replace them, but do not over-tighten. In addition to the cleaning mentioned for semi-weekly and monthly, the Combustion (exhaust) Blower should be removed annually and the blower tube vacuumed of any ash build-up. When cleaning or replacing the blower a new gasket (Part # PU-CBG) should be added between the blower flange and the steel exhaust tube.

**Soot and Fly ash: Formation and Need for Removal** – The products of combustion will contain small particles of fly ash. The fly ash will collect in the exhaust venting system and restrict the flow of flue gases. Incomplete combustion, such as occurs during startup, shutdown, or incorrect operation of the room heater will lead to some soot formation which will collect in the exhaust venting system. The exhaust venting system should be inspected at least once every year to determine if cleaning is necessary.

## MAINTENANCE

### **CAUTION: UNPLUG THE UNIT PRIOR TO ANY SERVICE WORK!**

SEE EXPLODED DIAGRAM (ILLUSTRATION 4) FOR PARTS REFERENCE

Parts Orders: (800) 516-3636 [www.englishstoveworks.com](http://www.englishstoveworks.com) Questions: (800) 245-6489

**NOTE:** Visit our web site for downloadable maintenance sheets and/or a service video that details and illustrates the following maintenance tasks.

### **Rear Panel Removal**

**WARNING:** To perform any maintenance inside the rear of the unit, the stove must be out (no fire), cooled down and unplugged. Electrical shock can occur if the unit is not unplugged from power.

To remove the rear panel, simply loosen the eight (8) screws (size 5/16") and flex the panel. The panel should come off without fully removing the screws.

Instructions for maintenance and part replacement procedures can be found on [www.englishstoveworks.com](http://www.englishstoveworks.com).

### **Auger Motors**

The Auger Motor and gearbox are one complete assembly (Part #PU-047040), and can be removed by disconnecting the power leads and loosening the ( $\frac{5}{16}$ " head) set bolt in front of the assembly. This bolt tightens down *on the flat side of the gear shaft* and locks the gear shaft and auger shaft together – once the bolt is loosened, the entire assembly will slide from the locking collar. There are two motor assemblies on the unit, and both rest on a shelf when not in operation. When replacing a motor, the assembly should always be placed to rest on this shelf prior to starting the unit.

### **Auger Bearings and Auger Shafts**

The auger bearings (Part #PU-UCF204-12) are a sealed unit and do not require lubrication. To replace the Top Auger, all the fuel must be removed from the hopper as well as from the Top Auger assembly. Once this is done, the four bolts that hold in the bearing can be removed, followed by the complete auger assembly. Loosen the two (2) set screws with a 1/8" allen wrench, which will disconnect the bearing from the shaft (the bearing assembly and auger assembly can be replaced by reversing this procedure). When placing the auger assemblies in the unit, always tighten the four bolts in a diagonal pattern to ensure the bearings and shafts are aligned properly.

**NOTE:** Follow the same procedure to work on the bottom auger, with the exception that the pellets do not have to be removed from the hopper.

### **Convection Blower**

The Convection (room air) Blower (Part #PU-4C447) is located on the left side of the unit and can be removed by disconnecting the power leads and removing the four mounting screws. Once this is done, the blower will slide out of the stove. This procedure can be reversed to install a new blower.

### **Combustion Blower**

To clean or replace the Combustion (exhaust) Blower (Part #PU-076002B), the power leads and the pellet vent pipe must be disconnected. Next, remove the screws that hold the blower to the steel exhaust tube and slide the blower from the stove. The blower impeller, blower tube and steel blower exhaust tube on the unit should be brushed and vacuumed. When cleaning or replacing the blower a new gasket (Part # PU-CBG) should be added between the blower flange and the steel exhaust tube.

### **Vacuum Switch**

This unit is equipped with Vacuum Shut Down Switches (Part # PU-VS and PU-VS-A), which help control various functions of the unit. If an operational error occurs in the unit, a switch will either stop the top (feed) auger or shut the unit off; if the unit turns off an E-1 Code (error code) will appear in the Heat Range and Blower Speed windows of the Control Board. Situations which could cause this include power failure, Combustion Blower failure, improper flue installation, a blocked flue (from rodents, nests, etc.), or “dirty burning” from burning improper fuel (see “Important Information” at the beginning of the manual).

### **Gaskets**

**IMPORTANT: IMPROPER GASKET MAINTENANCE, INCLUDING FAILURE TO REPLACE GASKETS, CAN CAUSE AIR LEAKS RESULTING IN SMOKE-BACKS.**

This unit comes with a 3/4” rope gasket around the door that should be replaced every two years. To replace the *door gasket* (Part # AC-DGKC), the old gasket must first be removed entirely — prior to adding the new adhesive, you may have to scrape the old cement from the door channel. Once the cement and gasket have been added, the door should be closed and latched for twenty-four hours to allow the cement to harden.

If you are replacing the *window gasket* (Part #AC-GGK), the new gasket will already have adhesive on one side. Remove the paper on the adhesive side and place the gasket around the outside edge of the glass by forming a “U” with your fingers and placing the gasket around the glass. You should also replace the *Combustion Blower gasket* (Part # PU-CBG) whenever you remove or clean the Combustion Blower.

### **Finish**

This new unit has been painted with High-Temperature Paint that should retain its original look for years. If the unit should get wet and rust spots appear, the spots can be sanded with plain steel wool and repainted. We recommend this paint, as others may not adhere to the surface or withstand the high temperatures.

### **Glass**

This unit has a 9” x 9” ceramic glass (Part #AC-G9, comes with gasket) in the viewing door. Surface scratches are acceptable and normal, but if this glass becomes cracked in any area, the unit should be shut down and the window replaced with this high-temperature ceramic glass.

## Control Board

The Control Board (Part #PU-CB04) is a digital read-out board. This board offers a wide variety of settings to operate the unit. This part can be removed from the unit by loosening the two outside screws and pulling the board back to the inside of the stove. The rear access panel should be removed prior to removing the control board. A 5-amp "quick-blow" fuse is used on this Control Board.

**NOTE:** The bottom three control buttons are preset at the factory and should *not* require any changes. See "Operating Instructions" and "Daily Operation" section of the manual for instructions on other Control Board settings.

### Recommended Heat Ranges:

Low Burn:	Heat Range setting: 1	Room Air Blower setting: 1
Medium Low:	Heat Range setting: 2 – 3	Room Air Blower setting: *
Medium High:	Heat Range setting: 5 – 8	Room Air Blower setting: *
High Burn:	Heat Range setting: 9	Room Air Blower setting: 9

\* NOTE: Blower Speed will automatically be adjusted to the desired Heat Range that you select.

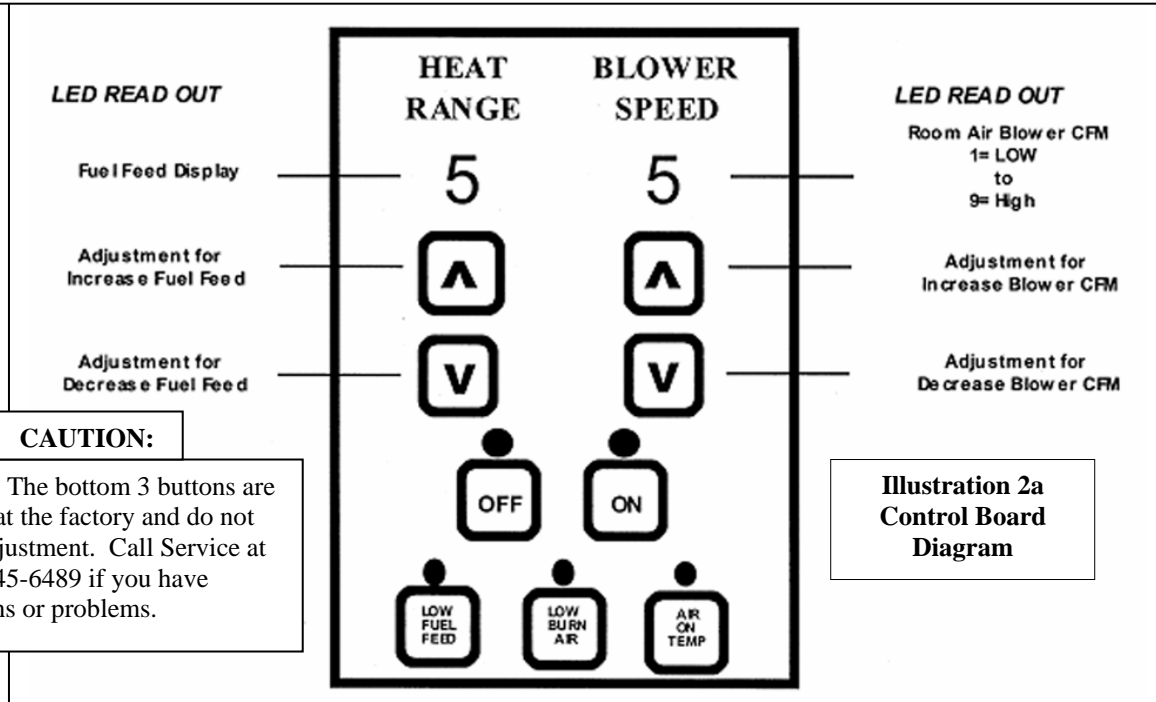

### CAUTION:

NOTE: The bottom 3 buttons are pre-set at the factory and do not need adjustment. Call Service at (800) 245-6489 if you have questions or problems.

Illustration 2a  
Control Board  
Diagram

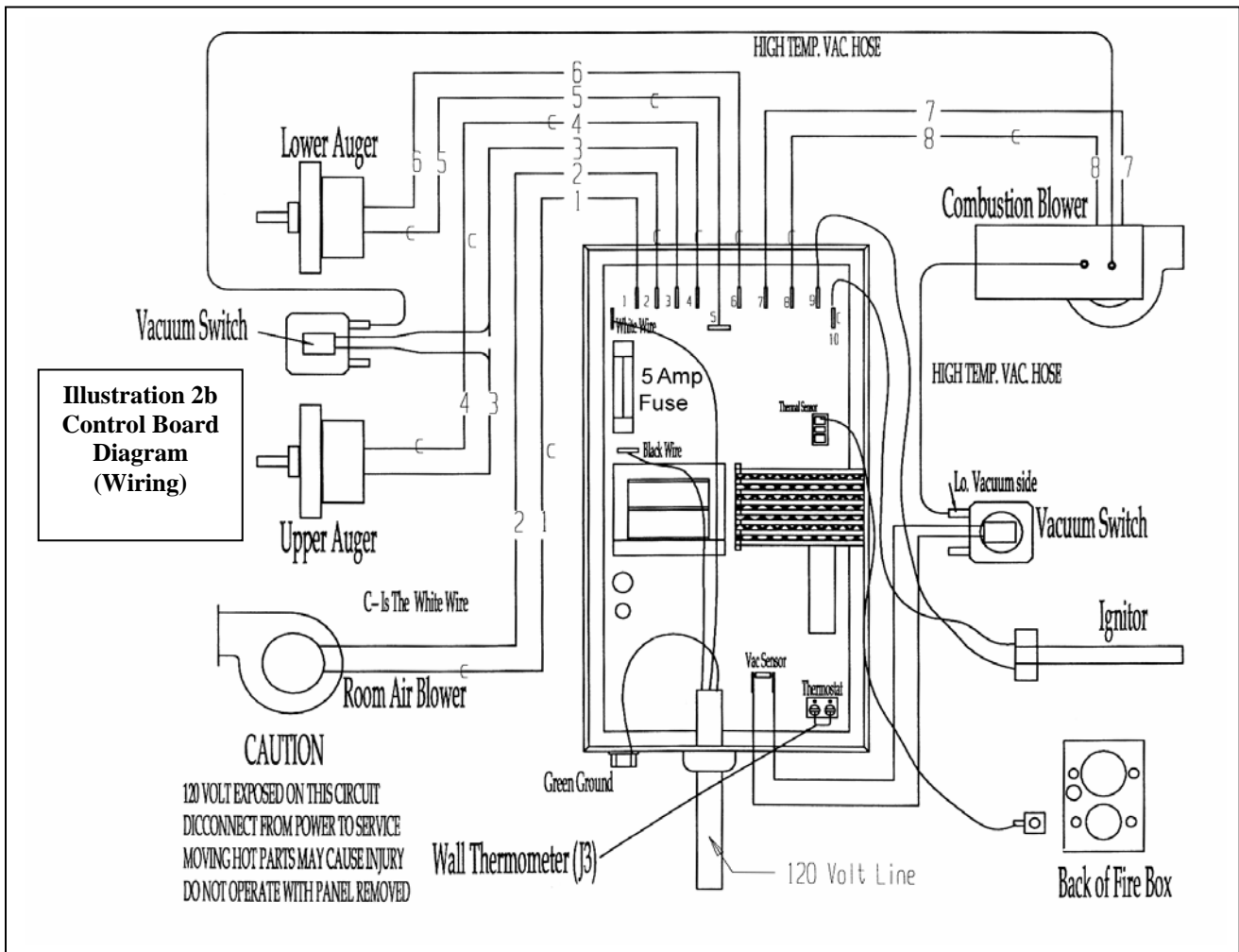

**CAUTION: Moving Parts May Cause Injury.  
Do NOT Operate with Panel(s) Off.**

**DANGER: Parts May Be Hot. Risk of Electric Shock.  
Disconnect Power Before Servicing Unit.**

**Notes on termination of Pellet Vent Pipe (see also "FLUE SYSTEM" section of manual):**

1. Not less than three (3) feet above any forced air inlet located within ten (10) feet.
2. Not less than four (4) feet below, four (4) feet horizontally from, or one (1) foot above any door, window or gravity air inlet into any building.
3. Not less than two (2) feet from an adjacent building, and not less than seven (7) feet above grade where located adjacent to public walkways.

The exhaust exit shall be arranged so that the flue gases are not directed so that it will affect people, overheat combustible structures, or enter buildings. Forced draft systems and all parts of induced draft systems under positive pressure during operation shall be installed gastight or to prevent leakage of combustion products into a building. Through-the-wall vents shall not terminate over public walkways, or where condensate or vapor could create hazards or a nuisance.

*Be sure to follow local codes and all manufacturer's instructions (including exhaust pipe). Consult a professional installer and/or call Customer Service if you have any questions.*

**IMPORTANT SAFETY NOTE:** If the unit or chimney connector pipe "glows" red (or white), the stove is over-fired. This condition could cause a house or chimney fire. Do not operate your unit too hot, or over-firing may result.



## **ACCESSORY ITEMS**

The following accessories can be added to your unit at anytime after purchase; however, let the unit cool down before adding any accessories.

### **Thermostats**

*WALL:* An external wall thermostat (such as our Part # GU-1E30-914) can be used on our pellet units as long as it is a low-voltage that works with millivolt systems. After unplugging the unit, locate the jumper wire (J-3) on the bottom of the control panel. The two screws should then be loosened and the jumper wire removed from the board. Next, the two thermostat lead wires should be slipped into these openings and the screws tightened; the jumper wire should be saved for future operation without a thermostat.

The unit will operate differently once the wall thermostat is connected – we recommend the Control Board be set at “9” on Heat Range and Blower Speed while using the thermostat. Refer to the section on “Start-up Procedure” for information on cold starts.

### **AC-103, AC-103BN Lip Trim**

There is one piece of J-Channel trim in this kit that snaps onto the ash apron lip of the stove. Match the channel with the correct edge of the ash apron, then remove the protective covering from the trim and force the piece onto the edge. Although it should stay in place, stove cement can be used to secure it if necessary.

*NOTE:* For stoves manufactured prior to 2001, the part number for this kit is AC-101-PU.

### **AC-106-P (SH-106-P), AC-106-PBN Window Trim**

This trim can be attached by using the provided spring clip and some high temperature silicone. Insert the tee end of the spring clip into the opening on the edge of the trim – this will allow the clip to fall into the groove. The spring clip will hold well if it is placed on the bottom edge of the trim. We also suggest that high temperature silicone be used on the corners, to ensure the trim will stay in place.

Accessories can be ordered from the factory at:  
(Parts orders ONLY) -- (800) 516-3636, or on our web site: [www.englishstoveworks.com](http://www.englishstoveworks.com) .  
*Questions/Problems:* Please call Customer Service at (800) 245-6489.

## REPLACEMENT PARTS, ACCESSORIES AND OPTIONS

AC-GGK	Glass Gasket Kit (gasket only, no glass)
AC-DGKC	Door Gasket Kit (#2 on diagram)
AC-114	Brass Louvers (#26 on diagram) (2001 and later Models; for earlier models call 800-245-6489 for AC-112 louvers)
AC-114BN	Nickel Louvers (#26 on diagram)
AC-G9	9" x 9" Glass <i>with</i> Gasket (#3 on diagram)
AC-SH	Brass Door Spring Handle
AC-SHN	Nickel Door Spring Handle
AC-MCSP	Hi-Temperature Charcoal Paint
AC-MBSP	Hi-Temperature Black Paint
PU-AMS	Auger Motor Support Gasket
PU-047040	1 RPM Auger Motor Assembly (#18 on diagram)
PU-BP98	Burn Pot Assembly
(#s 5 and 11 on diagram, call if you need only one part of this 2-piece assembly)	
PU-076002B	Combustion (Exhaust) Blower (includes 3" adapter) (#s 8 and 9 on diagram)
PU-4C447	Convection (Room Air) Blower (#13 on diagram) (2002 and later Models; for earlier models order PU-4C442)
PU-AF6T	Top Auger Shaft (#14 on diagram)
PU-AF11B	Bottom Auger Shaft (#14 on diagram) (2001 and later Models; for earlier models call for assistance)
PU-62-40-151-2	Hopper Lid Latch (2002 and later Models; for earlier models order PU-103-50) (#25 on diagram)
PU-UCF204-12	Auger Bearing (#16 on diagram)
PU-2X570	$\frac{3}{4}$ " Locking Collar (#17 on diagram)
PU-CB04	Digital Control Board (#12 on diagram)
PU-VS	Vacuum Shut-Down Switch (see Control Board diagram)
PU-VS-A	Second Vacuum Switch (see Control Board diagram)
PU-CBG	Combustion Blower Gasket (#10 on diagram)
PU-BPG	Burn Pot Gasket (#6 on diagram)
PU-ABG	Auger Bearing Gasket (#15 on diagram)
PU-HLG	Hopper Lid Gasket (#22 on diagram)
PU-CHA	Cartridge Heater (Igniter) Assembly (#27 on diagram)
<b>OPTIONS:</b>	
PU-OAK	Outside Air Kit
AC-3000	3" Pellet Vent Kit (Through-the-Wall)
AC-3100	4" Pellet Vent Kit (For High Altitudes – 4000+ ft.)
AC-3001	Remote Thermostat
GU-1E30-914	Wall Thermostat
AC-103	Brass Lip Trim for Ash Apron (2001 and later Models; for earlier models, order part # AC-101-PU.)
AC-103BN	Brushed Nickel Lip Trim for Ash Apron
AC-106-P/SH-106-P	Brass Window Trim
AC-106-PBN	Brushed Nickel Window Trim

*If you have any questions or problems contact the Customer Service Department:*

**Customer Service Department**

**P.O. Box 206  
Monroe, VA 24574**

[service@englanderstoves.com](mailto:service@englanderstoves.com)

**Parts Orders ONLY: 800-516-3636**

**Questions: 800-245-6489 (Fax: 434-929-4810)**

You may also order parts and options, view frequently asked questions and more, on our web site: [www.englishstoveworks.com](http://www.englishstoveworks.com)

## Pellet Stove – Exploded View Diagram

NUMBER	PART DESCRIPTION
1	Door (Part # CA-19A )
2	Door Gasket (Part # AC-DGKC )
3	Glass with Gasket (Part # AC-G9)
4	Impingement Plate*
5	Burn Pot
5a	Wear Plate for Burn Pot**
6	Burn Pot Gasket
7	Side Access Panel
8	Combustion Blower
9	3" Blower Adapter
10	Gasket for Combustion Blower Part # PU-CBG
11	Pellet Feeder Pot
12	Digital Control Board
13	Convection Blower
14	Augers: (Top Auger and Bottom Auger)
15	Block Bearing Gaskets
16	Block Bearings Part # PU-UCF204-12
17	3/4" I.D. Shaft Collars Part # PU-2X570
18	Auger Motors
19	Rear Access Panel
20	Hopper Flange Gasket Part # PU-HFG
21	Hopper
22	Hopper Lid Gasket Part # PU-HLG
23	Hopper Lid
24	Vacuum Shut Down Switch(es)
25	Hopper Lid Latches
26	Brass Louvers (Certain models only)
27	Cartridge Heater (Igniter) Assembly Part # PU-CHA

### NOTE ON PART NUMBERS:

This diagram is a basic England's Stove Works pellet unit diagram. Your model may vary somewhat. See our online store at [www.englishstoveworks.com](http://www.englishstoveworks.com) or the parts list in your manual for specific part numbers for your model stove. If a part is not listed in the manual or on the website, or if you have questions, call (800) 245-6489.

\*Note: Impingement Plate (4) hangs flush on back wall of firebox, and is centered over the burn pot.

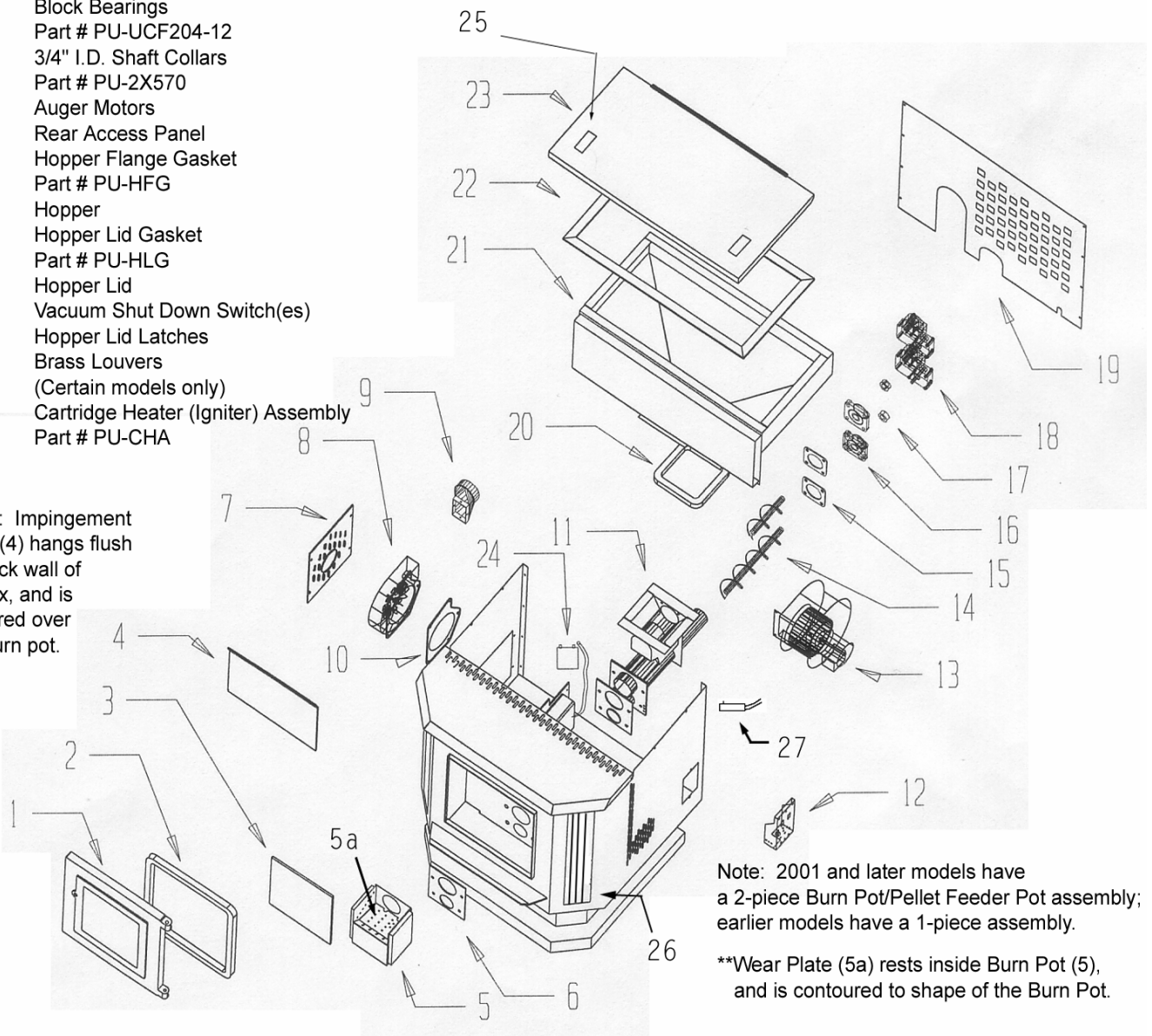

Note: 2001 and later models have a 2-piece Burn Pot/Pellet Feeder Pot assembly; earlier models have a 1-piece assembly.

\*\*Wear Plate (5a) rests inside Burn Pot (5), and is contoured to shape of the Burn Pot.

**Illustration 4**

## HOPPER LID LATCHES

**Illustration 3 –  
Hopper Lid Latches**

**Important: Hopper Lid Latches must be checked periodically and kept tight so the top is sealed to prevent back-burn.**

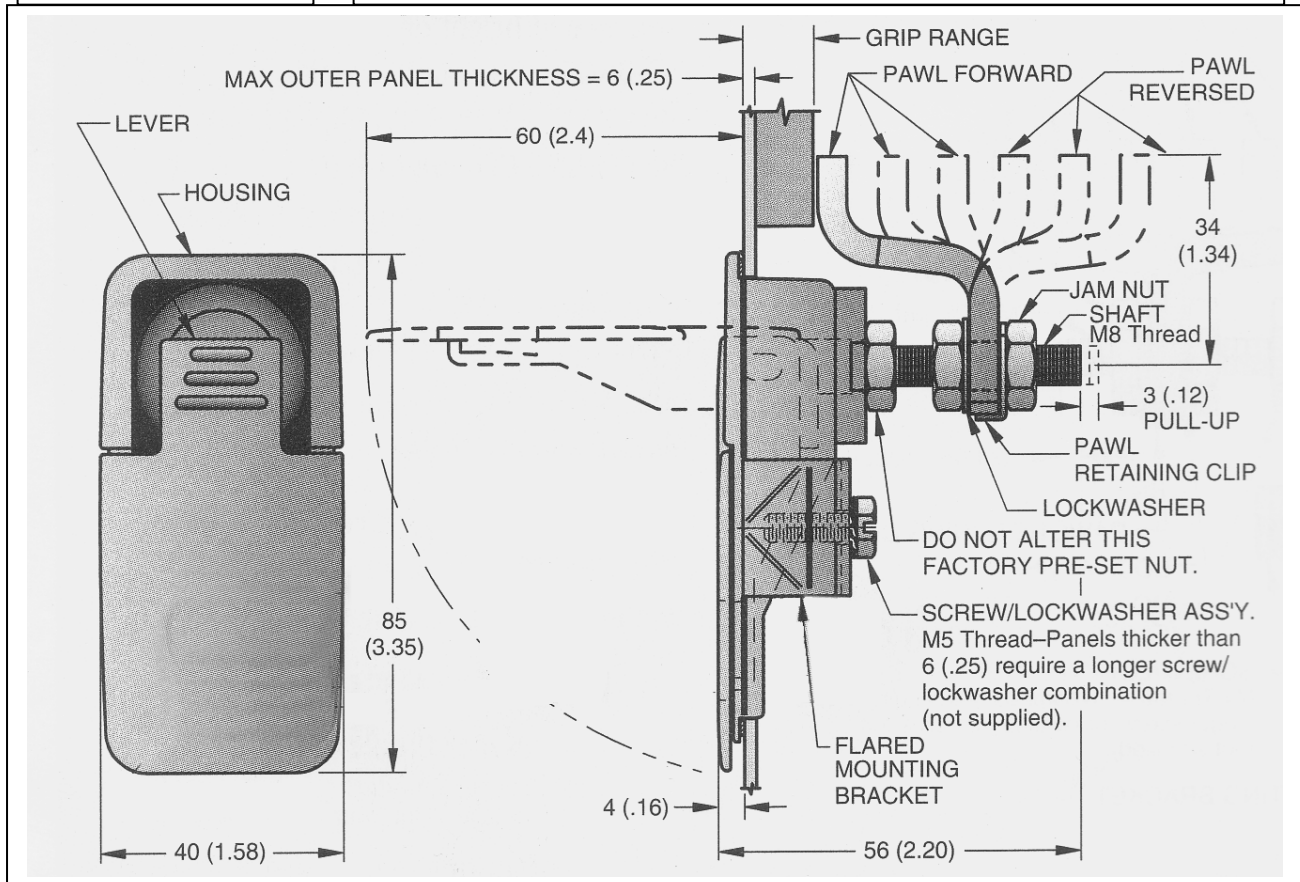

### Dimensions of your pellet unit:

28 ½"W x 30"H x 28 ½"D      375 lbs.  
(Approx. 13 ½" height from floor to center of exhaust)

### NOTES:

## TROUBLE-SHOOTING GUIDE

**WARNING: TO AVOID ELECTRICAL SHOCK ALWAYS *DISCONNECT* THE UNIT FROM THE POWER SOURCE BEFORE ATTEMPTING ANY REPAIR. IF THIS GUIDE DOES NOT CORRECT THE PROBLEM CALL YOUR LOCAL DEALER OR OUR CUSTOMER SERVICE AT 1-800-245-6489.**

<u>Problem</u>	<u>Cause</u>	<u>Solution</u>
1. Auger not turning	<ol style="list-style-type: none"> <li>1. Loose set screw</li> <li>2. Bad gear motor</li> <li>3. Foreign matter in auger</li> <li>4. Vacuum sensor (Top Auger)</li> </ol>	<ol style="list-style-type: none"> <li>1. Tighten setscrew on collar</li> <li>2. Replace auger motor</li> <li>3. Remove pellets and object</li> <li>4. Check exhaust blower</li> </ol>
2. Smoke smell or dust in house	<ol style="list-style-type: none"> <li>1. Improper exhaust connection</li> </ol>	<ol style="list-style-type: none"> <li>1. Check all connections for leaks especially the exhaust blower connection; Seal with silicone, hose clamp or aluminum tape</li> </ol>
3. Room air blower not operating	<ol style="list-style-type: none"> <li>1. Loose sensor</li> <li>2. High "ON" temperature</li> </ol>	<ol style="list-style-type: none"> <li>1. Tighten connection on sensor</li> <li>2. Adjust temperature lower</li> </ol>
4. Exhaust blower not operating (E-1 on Control Board)	<ol style="list-style-type: none"> <li>1. Loose connection</li> <li>2. Bad blower</li> <li>3. Bad vacuum sensor</li> </ol>	<ol style="list-style-type: none"> <li>1. Check connection at c/board</li> <li>2. Replace blower</li> <li>3. Replace vacuum sensor</li> </ol>
5. Lazy fire	<ol style="list-style-type: none"> <li>1. Control board settings</li> <li>2. Bad exhaust blower</li> <li>3. Excessive pellet moisture</li> <li>4. Excessive ash</li> <li>5. Low quality pellets</li> </ol>	<ol style="list-style-type: none"> <li>1. Review board settings</li> <li>2. Replace blower</li> <li>3. Keep pellets inside</li> <li>4. Remove baffles; Clean unit</li> <li>5. Use premium pellets</li> </ol>
6. Blown fuse (5 AMP)	<ol style="list-style-type: none"> <li>1. Power surge</li> <li>2. Exposed wire</li> <li>3. Electric motor shorting or bound up</li> </ol>	<ol style="list-style-type: none"> <li>1. Replace fuse; use surge protector</li> <li>2. Check for exposed or frayed wire and loose connections</li> <li>3. Check motors and blowers for obstructions or lock-up</li> </ol>
7. High pellet consumption	<ol style="list-style-type: none"> <li>1. Low quality pellets</li> <li>2. Board out of adjustment</li> </ol>	<ol style="list-style-type: none"> <li>1. Use premium fuel</li> <li>2. Check c/board settings</li> </ol>
8. Squeaking noise	<ol style="list-style-type: none"> <li>1. Build up in tube</li> <li>2. Improper auger alignment</li> <li>3. Blower noise</li> </ol>	<ol style="list-style-type: none"> <li>1. Remove auger and clean</li> <li>2. Re-align auger</li> <li>3. Remove and oil blower</li> </ol>
9. Pinging or rattling noise	<ol style="list-style-type: none"> <li>1. Foreign material</li> <li>2. Loose set screw</li> </ol>	<ol style="list-style-type: none"> <li>1. Check blower for material</li> <li>2. Check impeller blower screw</li> </ol>
11. Unit keeps shutting down ("E" codes on control board)	<ol style="list-style-type: none"> <li>1. Blocked flue (E-1)</li> <li>2. Blower failure (E-3)</li> <li>3. Improper installation* (E-1)</li> </ol>	<ol style="list-style-type: none"> <li>1. Check for flue blockage (nests, rodents, excess soot, etc.)</li> <li>2. Check combustion blower wires, then call Cust. Svc.</li> <li>3. Check for loose flue/pipe connections. Also be sure to have proper Outside Air hook-up.</li> </ol>

\*Improper installation may cause a back draft.

\*NOTE: Also check for loose or cracked vacuum hose on vacuum switches (see #24 in Illustration 4).

Have this information on hand if you phone the factory or your dealer regarding this product.

Retain for your files:

Model Number \_\_\_\_\_

Date of Purchase \_\_\_\_\_

Date of Manufacture \_\_\_\_\_ Serial # \_\_\_\_\_

## **LIMITED 5 YEAR WARRANTY FROM THE DATE OF PURCHASE TO THE ORIGINAL OWNER**

The manufacturer extends the following warranties:

### **Five Year Period:**

1. Carbon steel and welded seams in the firebox are covered for 5 years against splitting.
2. The cast iron door and hinges are covered for 5 years against cracking.

### **Three Year Period:**

3. Component parts such as the hopper, auger burn pot, baffle plate, auger shafts, auger bearings, and fasteners are covered for 3 years against cracking, breakage and welded seams from separating.

### **One Year Period:**

4. Electrical components, accessory items, glass and the painted surface are covered for 1 year from the date of purchase.

### **Conditions and Exclusions:**

Damage from over-firing will void your warranty.

This warranty does not apply if damage occurs because of an accident, improper handling, improper installation, improper operation, abuse, or unauthorized repair made or attempted to be made.

The manufacturer is not liable for indirect, incidental, or consequential damages in connection with the product including any cost or expense providing substitute equipment or service during periods of malfunction or nonuse.

All liability for any consequential damage for breach of any written or implied warranty is disclaimed and excluded. Some states do not allow the exclusion or limitations of incidental or consequential damages, so the above may not apply to you.

### **Procedure:**

Purchaser must give notice of claim of defect within the warranty period and pay transportation to and from a service center designated by the factory. The dealer from which the unit was purchased or the factory, at our option, will perform the warranty service.

### **Other Rights:**

This warranty gives you specific legal rights, and you may also have other rights, which may vary from state to state.

**NOTE: THIS WARRANTY IS NULL AND VOID IF YOU DO NOT RETURN THE ATTACHED WARRANTY REGISTRATION WITH A COPY OF THE SALES RECEIPT WITHIN 30 DAYS FROM THE DATE OF PURCHASE. WARRANTY IS NOT TRANSFERABLE**

**WARRANTY REGISTRATION for England's Stove Works**

Purchased by (Name) \_\_\_\_\_

Address \_\_\_\_\_

City \_\_\_\_\_ State \_\_\_\_\_ Zip \_\_\_\_\_

Telephone \_\_\_\_\_

Email Address \_\_\_\_\_

**DEALER INFORMATION**

Purchased From (Dealer) \_\_\_\_\_

Address \_\_\_\_\_

City \_\_\_\_\_ State \_\_\_\_\_ Zip \_\_\_\_\_

**UNIT INFORMATION –**

**(Please be sure to refer to sticker on back of manual or box to complete this section)**

Model Number \_\_\_\_\_ Purchase Date \_\_\_\_\_

Purchase Price \_\_\_\_\_

Serial Number \_\_\_\_\_ Mfg. Date \_\_\_\_\_

*How did you first hear about our product? (please check one)*

Word of Mouth                       Burn Trailer Demonstration                       Internet

Other: \_\_\_\_\_

*Where did you receive information about our product? (please check one)*

Rec'd. info. via phone                       Dealer (Name of dealer): \_\_\_\_\_

Internet                      Other: \_\_\_\_\_

**IMPORTANT NOTICE**

**THIS REGISTRATION INFORMATION MUST BE ON FILE FOR THIS WARRANTY TO BE VALID.  
PLEASE MAIL THIS INFORMATION WITHIN THIRTY (30) DAYS FROM THE DATE OF PURCHASE.**

Mail To:

England's Stove Works, Inc.  
Customer Service Department  
P.O. Box 206  
Monroe, VA 24574

Or, Fax To:

(434) 929-4810 – 24 hours a day

Or, now available – Go online to complete your Warranty Registration!

Visit [www.englishstoveworks.com](http://www.englishstoveworks.com) if you prefer to register online.

